



WHITE KNIGHT
.....engineer approved™

PSB SERIES PUMPS

High Flow Chemical Delivery

PSB100 air-operated double-diaphragm (AODD) pumps feature PTFE/PFA fluid paths for high-purity chemical delivery, dispense and transfer applications. They are capable of 95 lpm (25 gpm) flow rates and 5.5. Bar (80 psi) air supply pressures. PSB100 pumps are a direct retrofit for other delivery pumps.

ADVANCED PUMP TECHNOLOGIES

Tongue-&-Groove
Check Caps Seals

No Exposed Metals

PTFE/PFA
Fluid Path

Max Flow
95 lpm (25 gpm)

Max Temp.
100°C (212°F)

Max Pressure
5.5 Bar (80 psi)

Shift Method
Internal shuttle

Industries
Semiconductor
LEDs & Electronics
Flat-Panel Displays
Photovoltaic / Solar
Aerospace

Applications
Chemical Delivery
Chemical Circulation
Chemical Dispense
Chemical Reclaim
Bulk Transport
CMP Slurry

Internal,
Non-Stall
Shuttle Valve

Fitting Options

Quick-Install
Base Plate

Features & Benefits

- Leak-free check caps with tongue-&-groove seals
- High-density PTFE prevents frequent tie bolt retorque
- Durable machined design with minimal parts
- Process-safe PTFE, PFA fluid paths ideal for high-purity chemicals
- Reliable, safe operation; No exposed metals
- Internal, non-stall shuttle valve saves space and eliminates resets
- Pneumatic Logic™ provides dead-head operation without stall
- Various liquid connection styles and sizes

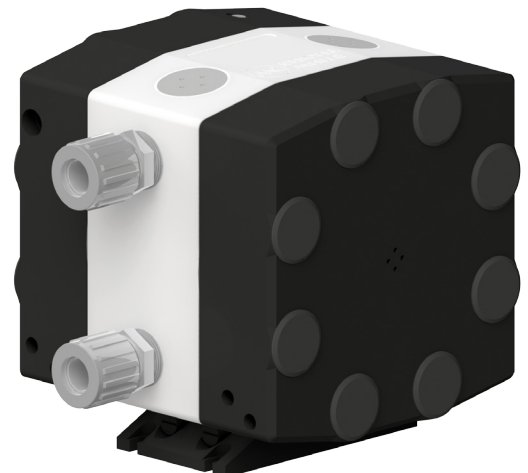

Additional ports available on back.





Performance

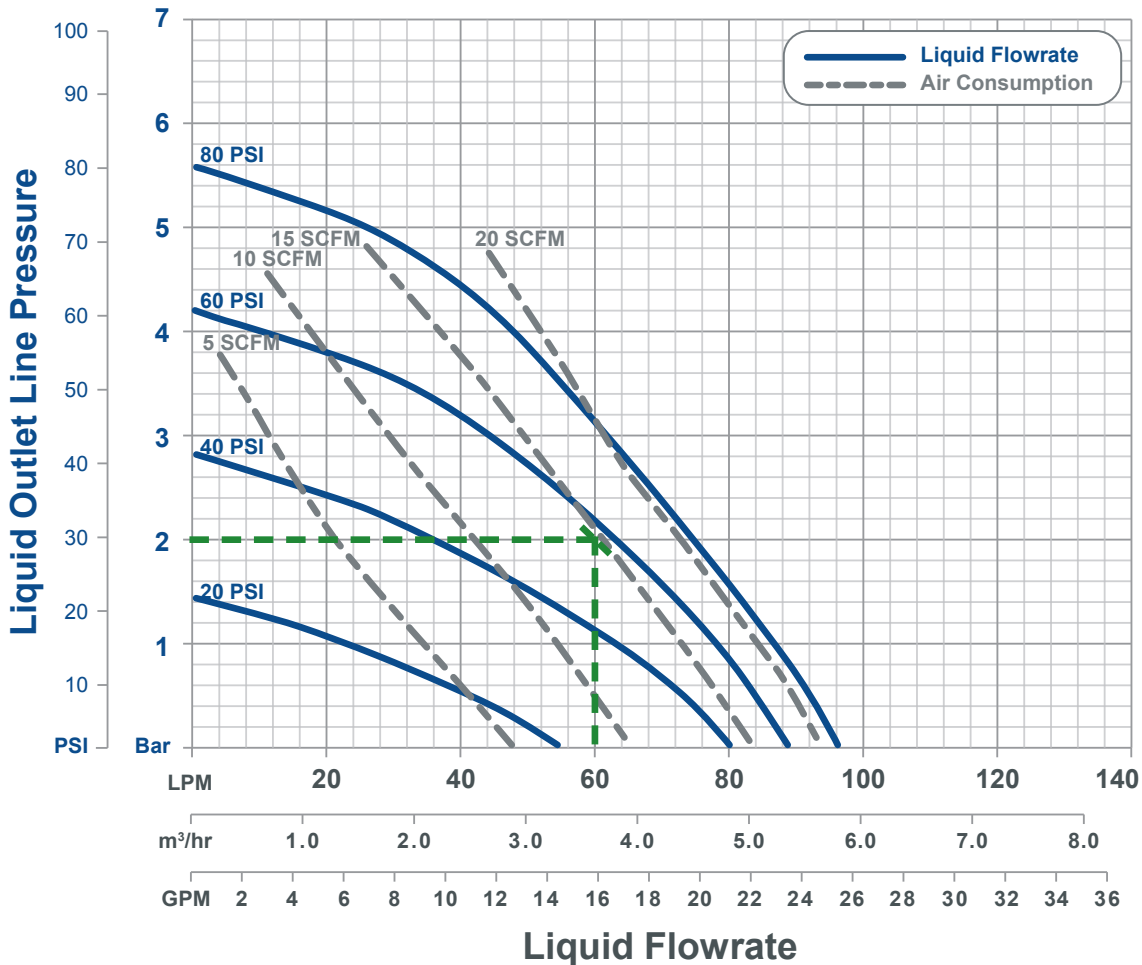

Dimensions

Dimensions in inches [mm]

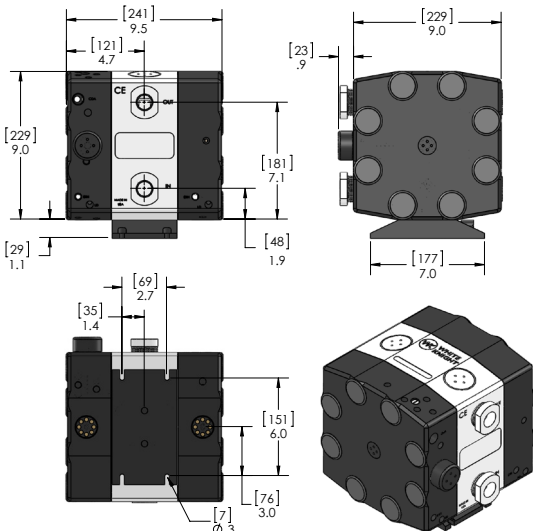

Specifications

Max Fluid Flow Rate	95 lpm (25 gpm)
Displacement Per Cycle*	0.074 liters 0.042 gal.
Cycles per min	170 max
Air Connection	1/2 in. FNPT
Suction Lift*	3 m (10 ft.)
Weight	15.7 kg (34.7 lbs.)

Max Air/Fluid Temperature	100°C (212°F)
Max Supply Air Pressure	5.5 Bar (80 psi)
Min. Startup Air Pressure	1.4 bar (20 psi)
Fluid Path Materials	PTFE, PFA

Stroke Detection	Fiber optic with or without D10 sensor, or solid state pressure switch (NPN or PNP)
Leak Detection	Fiber optic with or without sensor, or conductivity
Electronic Control	CPC, CPT, or custom. Contact White Knight.

