



ENIB Co., Ltd.

# ACA MANUAL VALVE

ABSOLUTE CHEMICAL APPLICATION- FERRULE CONNECTION TYPE

## OVERVIEW

ACA Manual valve is made only of Fluoropolymer material and is designed to generate optimal performance in handling high-purity chemicals.

## FEATURES

1. Based on GCA valve design
2. Suitable for handling strong acid and for preventing discoloration of non-flow stream components from chemical fume. Key parts are made of PFA material- valve body, bonnet, and fitting nut
3. Bonnet Lock and fitting Nut Lock stabilize and prevent loosening of valve components adding additional safety
4. Visually identifiable on and off indicator for precise valve operation

## TECHNICAL DATA

Actuator Type	Manual Handle Operation
Connection Type	ENIB Ferrule Connection
Configuration	2-Way Flow / Orifice

Model Number	Size	Orifice	Cv	Port Configuration
AMV-FR-04	1/4"	4.5	0.5	1/4" Ferrule Connection
AMV-FR-06	3/8"	6.9	1.1	3/8" Ferrule Connection
AMV-FR-08	1/2"	10	1.8	1/2" Ferrule Connection
AMV-FR-12	3/4"	16.4	5.8	3/4" Ferrule Connection
AMV-FR-16	1"	22.8	11	1" Ferrule Connection
AMV-FR-20	1-1/4"	28	14	1-1/4" Ferrule Connection

Operating Temperature	Operating Pressure
0 ~ 90 °C	9kg/cm <sup>2</sup> (0.9Mpa)
90 ~ 120 °C	7kg/cm <sup>2</sup> (0.7Mpa)

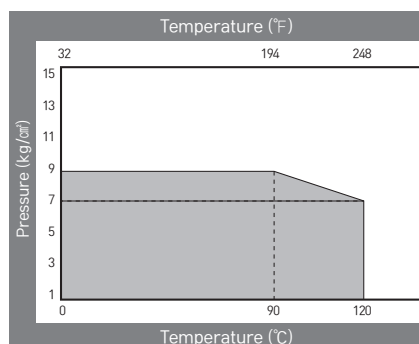

Standard Ferrule Type Size  
1/4" ~ 1-1/4"

## 2-WAY FLOW PATTERNS

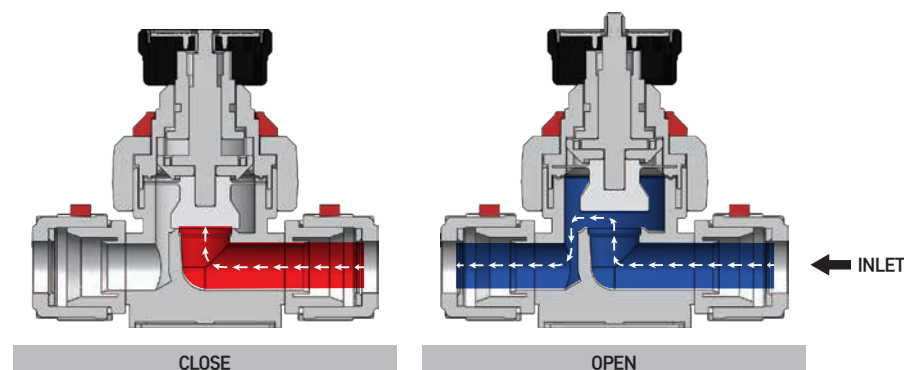

## MATERIAL CONSTRUCTION & DIMENSION TABLE

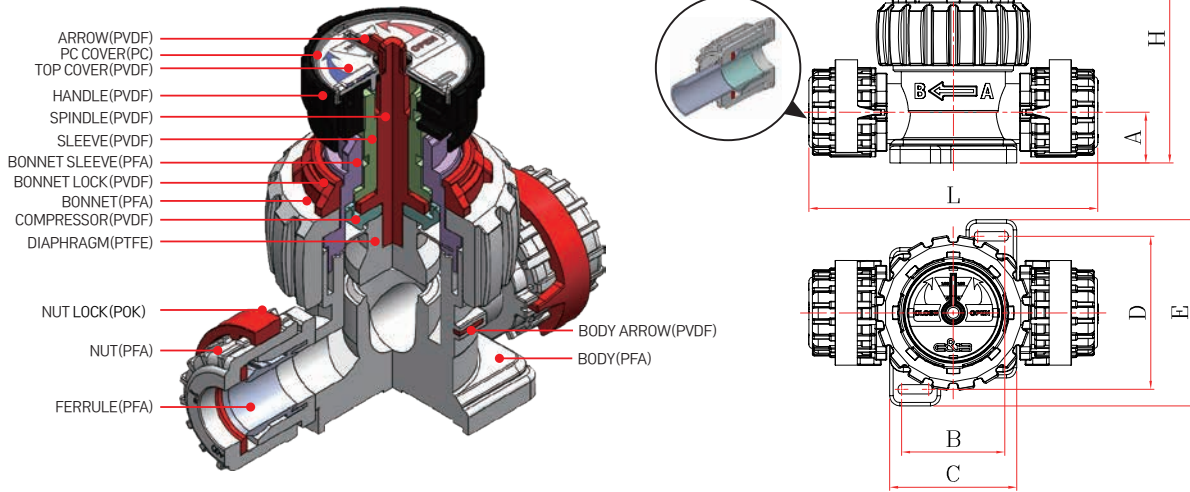

Size	A	H	L	B	C	D	E
1/4"	0.71"(18mm)	3.64"(92.5mm)	3.94"(100mm)	1.14"(29mm)	1.61"(41mm)	1.89"(48mm)	2.48"(63mm)
3/8"	0.71"(18mm)	3.64"(92.5mm)	4.33"(110mm)	1.14"(29mm)	1.61"(41mm)	1.89"(48mm)	2.48"(63mm)
1/2"	0.87"(22mm)	4.21"(107mm)	4.74"(120.5mm)	1.34"(34mm)	1.81"(46mm)	2.17"(55mm)	2.76"(70mm)
3/4"	1.18"(30mm)	5.28"(134mm)	5.63"(143mm)	1.73"(44mm)	2.24"(57mm)	2.56"(65mm)	3.15"(80mm)
1"	1.18"(30mm)	5.79"(147mm)	6.71"(170.5mm)	2.40"(61mm)	2.95"(75mm)	3.56"(90.5mm)	4.33"(110mm)
1-1/4"	1.50"(38mm)	6.28"(159.5mm)	8.39"(213mm)	2.40"(61mm)	2.95"(75mm)	3.52"(89.5mm)	4.21"(107mm)

## HOW TO ORDER

Type	CODE
------	------

ACA MANUAL VALVE      AMV

Connection	CODE
------------	------

FERRULE      FR

SIZE	CODE
------	------

1/4"      04

3/8"      06

1/2"      08

3/4"      12

1"      16

1-1/4"      20

Example : AMV-FR-16

AMV	ACA MANUAL VALVE
FR	FERRULE
16	1"

## “ SMART VALUE OPERATION PRODUCT LINE UP ”

### ENIB (Extrusion & Injection, Basic Co., Ltd) Corporate Mission :

ENIB is to become a key provider of safe, high performance, and advanced technology device and components for fluid management systems and applications that meet or exceed the needs and requirements of global customers.

62, BANSAN 2-RO, MUNMAK-EUP, WONJU-SI,  
GANGWON-DO, REPUBLIC OF KOREA  
Customer Service Tel : +82 033-743-9200  
Customer Fax : +82 033-743-9201  
www.enib.co.kr