

LINED PNEUMATIC VALVE

WEIR TYPE - PIPE TYPE

OVERVIEW

Lined Diaphragm Series Valve's diaphragm is made of high-purity fluoropolymer material and maintains excellent airtightness due to its specialized design structure. It is used as a control valve for equipment and pressure vessels that supply high purity chemical lines in the semiconductor and LCD industries.

TECHNICAL DATA

Actuator Type	Pneumatic Air Operate
Connection Type	ENIB Pipe Connection
Configuration	2-Way Flow / Weir Type
JIS 10KG flange type	15A, 20A, 25A, 40A, 50A
ANSI 150LBS	JIS 10K 와 동일
DINPN16	JIS 10K 와 동일
Air Port	1/8" PT (FEMALE)
Supply Pressure	6kg/cm ² (0.6Mpa) ~ 7kg/cm ² (0.7Mpa)

Operating Temperature	Operating Pressure
0~90°C	9kg/cm ² (0.9Mpa)
90~120°C	7kg/cm ² (0.7Mpa)

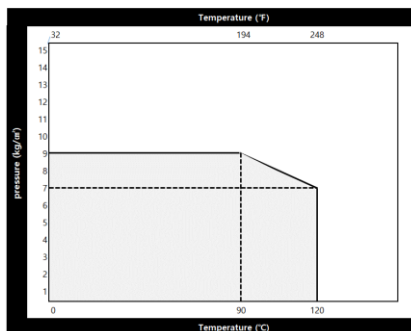

3-WAY FLOW PATTERNS

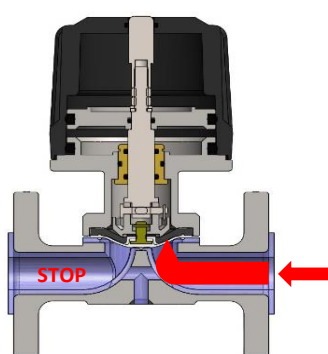

CLOSE

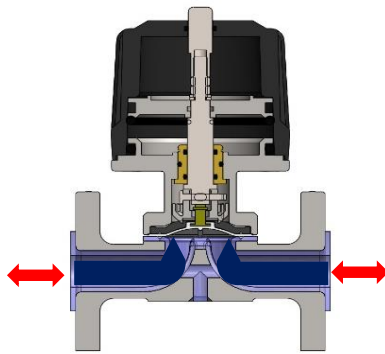

OPEN



ENIB Co.,Ltd.



MATERIAL CONSTRUCTION & DIMENSION TABLE

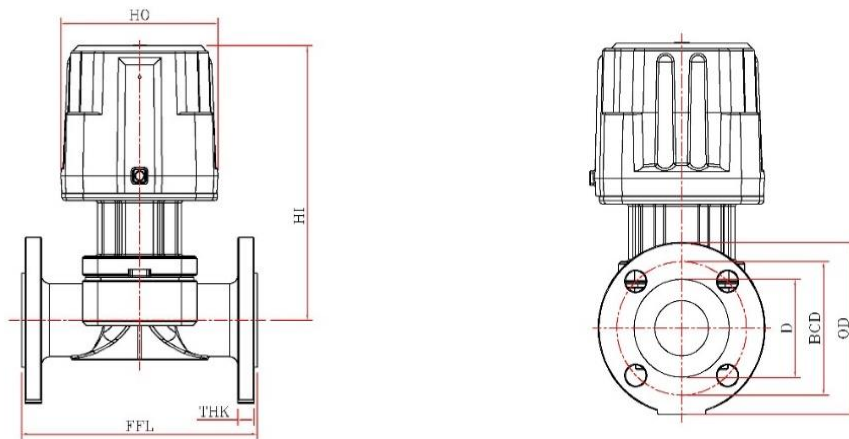
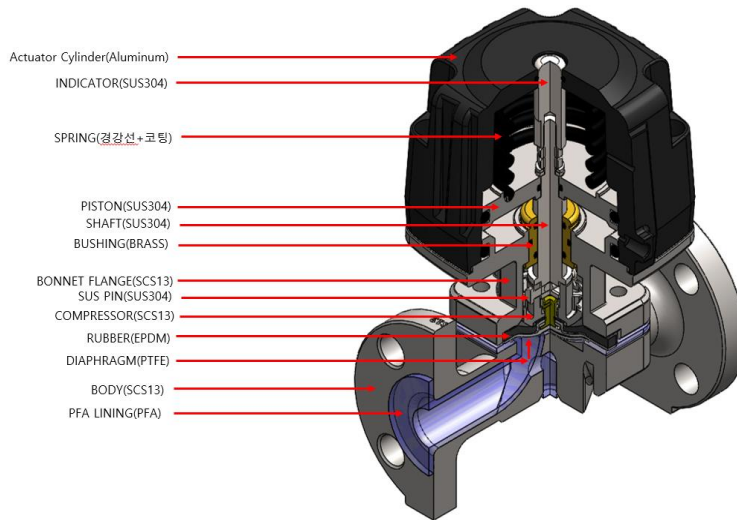

SIZE	FFL	HI	HO	BCD	OD	THK	D
JIS 15A	5.91"(150mm)	6.22"(158mm)	4.06"(103mm)	2.76"(70mm)	3.74"(95mm)	0.47"(12mm)	1.89"(48mm)
JIS 20A	5.91"(150mm)	6.22"(158mm)	4.06"(103mm)	2.38"(60.4mm)	3.50"(88.9mm)	0.44"(11.2mm)	1.54"(39mm)
JIS 25A	5.91"(150mm)	6.22"(158mm)	4.06"(103mm)	2.95"(75mm)	3.94"(100mm)	0.55"(14mm)	1.97"(50mm)
JIS 40A	6.3"(160mm)	6.81"(173mm)	4.13"(105mm)	3.54"(90mm)	4.92"(125mm)	0.55"(14mm)	2.4"(61mm)
JIS 50A	7.87"(200mm)	8.46"(215mm)	5.08"(129mm)	4.13"(105mm)	5.51"(140mm)	0.63"(16mm)	2.76"(70mm)
ANSI 1/2"	9.06"(230mm)	10.04"(255mm)	6.02"(153mm)	4.72"(120mm)	6.1"(155mm)	0.63"(16mm)	3.46"(88mm)
ANSI 3/4"	5.91"(150mm)	6.22"(158mm)	4.06"(103mm)	2.75"(69.9mm)	3.88"(98.5mm)	0.5"(12.7mm)	1.97"(50mm)
ANSI 1"	6.3"(160mm)	6.81"(173mm)	4.13"(105mm)	3.12"(79.2mm)	4.25"(108mm)	0.56"(14.2mm)	2.4"(61mm)
ANSI 1.5"	7.87"(200mm)	8.46"(215mm)	5.08"(129mm)	3.88"(98.5mm)	5"(127mm)	0.69"(17.5mm)	2.76"(70mm)
ANSI 2"	9.06"(230mm)	10.04"(255mm)	6.02"(153mm)	4.75"(120.6mm)	6"(152.5mm)	0.75"(19.1mm)	3.46"(88mm)
DIN 20D	5.91"(150mm)	6.22"(158mm)	4.06"(103mm)	2.95"(75mm)	4.13"(105mm)	0.63"(16mm)	1.97"(50mm)
DIN 25D	6.3"(160mm)	6.81"(173mm)	4.13"(105mm)	3.35"(85mm)	4.53"(115mm)	0.63"(16mm)	2.4"(61mm)
DIN 40D	7.87"(200mm)	8.46"(215mm)	5.08"(129mm)	4.33"(110mm)	5.91"(150mm)	0.63"(16mm)	2.76"(70mm)
DIN 50D	9.06"(230mm)	10.04"(255mm)	6.02"(153mm)	4.92"(125mm)	6.5"(165mm)	0.71"(18mm)	3.46"(88mm)

HOW TO ORDER

Product Name	CODE
LINED PNEUMATIC VALVE	LPV

Code Size	CODE
15A or 1/2"	15
20A or 3/4"	20
25A or 1"	25
40A or 1-1/2"	40
50A or 2"	50

Connection Type	CODE
JIS10K	J
ANSI150LBS	A
DINPN16	D

Surface	CODE
ACID	AC
IVORY	IV
WHITE	WH
GRAY	GR

Example : **LPV-40-J-AC**

LPV	LINED PNEUMATIC VALVE
40	40A
J	JIS
AC	ACID

“ SMART VALUE OPERATION PRODUCT LINE UP ”

ENIB(Extrusion & Injection, Basic Co., Ltd) Corporate Mission :

ENIB is to become a key provider of safe, high performance, and advanced technology device and components for fluid management systems and applications that meet or exceed the needs and requirements of global customers.

62, Bansan 2-ro, Munmak-eup, Wonju-si,
Gangwon-do, Republic of Korea
Customer Service Tel : +82. 033. 743. 9200
Customer Fax : +82. 033. 743. 9201
www.enib.co.kr